

AN-311 Theory and Applications of Logarithmic Amplifiers

ABSTRACT

A number of instrumentation applications can benefit from the use of logarithmic or exponential signal processing techniques. The design and use of logarithmic/exponential circuits are often associated with involved temperature compensation requirements and difficult to stabilize feedback loops. For these considerations and others, designers tend to avoid these circuits. Hybrid and modular logarithmic/exponential devices are available commercially, but are quite expensive and earn very high profits for their manufacturers.

Contents

1	Theory and Applications of Logarithmic Amplifiers	2
2	References	9

List of Figures

1	Logarithmic Amplifier	2
2	Exponentiator Driven by Biasing a Voltage Output Amplifier	3
3	Exponentiator, Composed of Q1 and A1A, is Driven From Input Amplifier A1D	4
4	Output Traces	5
5	Exponentiator With More Accurate V-F Converter	6
6	Exponentiator Circuit Used in a Non-Invasive, High Reliability Gas Gauge	7
7	Output Traces	8
8	Optically Split Light Source	9

1 Theory and Applications of Logarithmic Amplifiers

The theory and construction of these circuits are actually readily understood. Figure 1 shows an amplifier that provides a logarithmic output for a linear input current or voltage. For input currents, the circuit will maintain 1% logarithmic conformity over almost six decades of operation. This circuit is based, as are most logarithmic circuits, on the inherent logarithmic relationship between collector current and V_{BE} in bipolar transistors. Q1A functions as the logging transistor in this circuit and is enclosed within A1A's feedback loop, which includes the 15.7 k Ω -1 k Ω divider. The circuit's input will force A1A's output to achieve whatever value is required to maintain its summing junction at zero potential. Because Q1A's response is dictated by the logarithmic relationship between collector current and V_{BE} , the output of A1A will be the logarithm of the circuit input. A1B and Q1B provide compensation for Q1A's V_{BE} temperature dependence. A1B servos Q1B's collector current to equal the 10 μ A current established by the LM329 reference diode and the 700 k Ω resistor. Since Q1B's collector current cannot vary, its V_{BE} is also fixed. Under these conditions only Q1A's V_{BE} will be affected by the circuit's input. The circuit's output is a function of:

$$E_{OUT} = \frac{15.7k + 1k}{1k} (V_{BEQ1B} - V_{BEQ1A}) \quad (1)$$

For Q1A and Q1B operating at different collector currents, the V_{BE} difference is:

$$\Delta V_{BE} = \frac{KT}{q} \log_e \frac{I_{CQ1A}}{I_{CQ1B}} \quad (2)$$

where — K=Boltzmann's constant

— T=temperature $^{\circ}$ K

— q=charge of an electron.

If both equations are combined, the circuit output for a voltage input is:

$$E_{OUT} = \frac{-KT}{q} \frac{15.7k + 1k}{1k} \log_e \frac{E_{IN} \cdot 700k}{6.9V \cdot 100k} \quad (3)$$

where — 6.9V= V_z of LM329

— 100k=input resistor

— $E_{IN} \geq 0$.

This confirms that the circuit output voltage is logarithmically related to the circuit's input. Without some form of compensation, the scale factor will change with temperature. The simplest way to avoid this is to have the 1 k Ω value vary with temperature. For the device shown, compensation is within 1% over -25° C to $+100^{\circ}$ C. The circuit's gain is set by the 15.7 k Ω -1 k Ω divider, to a factor of 1V/decade.

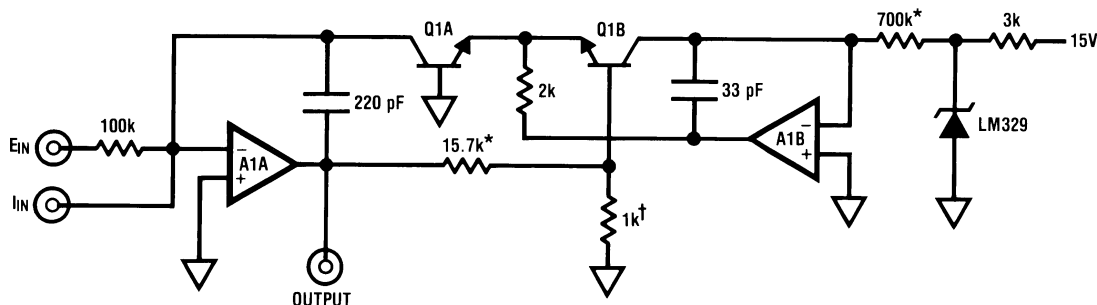

*1% film resistor

†1 k Ω ($\pm 1\%$) at 25° C, $+3500$ ppm/ $^{\circ}$ C.

Available from Vishay Ultronix,
Grand Junction, CO, Q81 Series.

A1A, A1B = LF412 dual

Q1A, Q1B = LM394 dual

Figure 1. Logarithmic Amplifier

This circuit can be easily turned around to generate exponentials. In Figure 2, Q1A is driven from the input via the 15.7 kΩ divider. Q1B's collector current varies exponentially with its V_{BE} , and A1B provides a voltage output representation of this action.

These circuits are easy to construct and use if a few considerations are kept in mind. Because of the V_{BE} and scale factor temperature dependences, it is important that Q1A, Q1B and the 1 kΩ resistor be kept at the same temperature. Since Q1 is a dual monolithic device, both halves will track. The resistor should be mounted as closely as possible to Q1, and these components should be kept away from air currents or drafts. The KT/q factor for which the resistor compensates varies at about 0.3%/°C, so a few degrees difference between Q1 and the resistor will introduce significant error.

Once the theory and construction techniques are understood, the circuits can be applied. Figure 3 shows a way to achieve very precise control of a rotary pump, used to feed a biochemical fermentation process. In this example, the exponentiator, composed of Q1 and A1A, is driven from input amplifier A1D. Q1B's collector current, instead of biasing a voltage output amplifier as in Figure 2, pulls current from the A1B integrator that ramps up (trace A, Figure 4) until it is reset by level triggered A1C (A1C output is trace B, Figure 4). The 100 pF capacitor provides AC positive feedback to A3C's "+" input (trace C, Figure 4). The magnitude of the current that Q1B's collector pulls from A1B's summing junction will set the frequency of operation of this oscillator. Note that the operation of the exponentiator is similar to the basic circuit in Figure 3 because A1B's summing junction is always at virtual ground. A1C's output drives the MM74C76 flip-flop to bias the output transistors with 4-phase drive for a stepper motor that runs the pump head. In practice, the exponentiator allows very fine and predictable control for very slow pump rates (for example, 0.1 rpm-10 rpm of the stepper motor), aiding tight feedback control of the fermentation process. When high pump rates are required, such as during process start-up or when a wide feedback control error exists, the exponentiator can be voltage directed to the top of its range. To calibrate the circuit, ground V_{IN} and adjust the 0.1 Hz trim until oscillation just ceases. Next, apply 7.5 V at V_{IN} and adjust the 600 Hz trim for 600 Hz output frequency. Figure 5 shows a circuit similar to Figure 3, except that a more accurate V-F converter is used. This circuit is intended for laboratory and audio studio applications requiring an oscillator whose frequency changes exponentially with an applied input sweep voltage. Applications include swept distortion measurements (where this circuit's output is used to drive a sine coded ROM-DAC combination or analog shaper) and music synthesizers. The V-F converter employed allows better than 0.15% total conformity over a range of 10 Hz-30 kHz. The voltage reference used to drive A1A's input resistor is derived from the LM331A's internal reference and is scaled by A1B, which also biases the zero trim setting. The DM74C74 provides a square wave output for applications requiring a waveform with substantial fundamental frequency content. The 0.15% conformity performance achieved by this circuit will meet almost any synthesizer or swept distortion measurement and the scale factor may be easily varied. To trim, apply OV to the input and adjust zero until oscillation (typically 2 Hz-3 Hz) just starts. Next, apply -8 V and adjust the 5k unit for an output frequency of 30 kHz. For the values given, the K factor of the exponentiator will yield a precise doubling in frequency for each volt of input (for example, 1 V in per octave out).

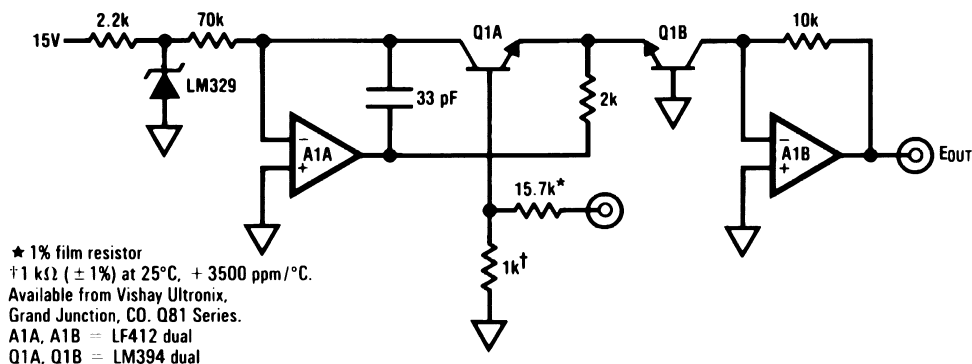

Figure 2. Exponentiator Driven by Biasing a Voltage Output Amplifier

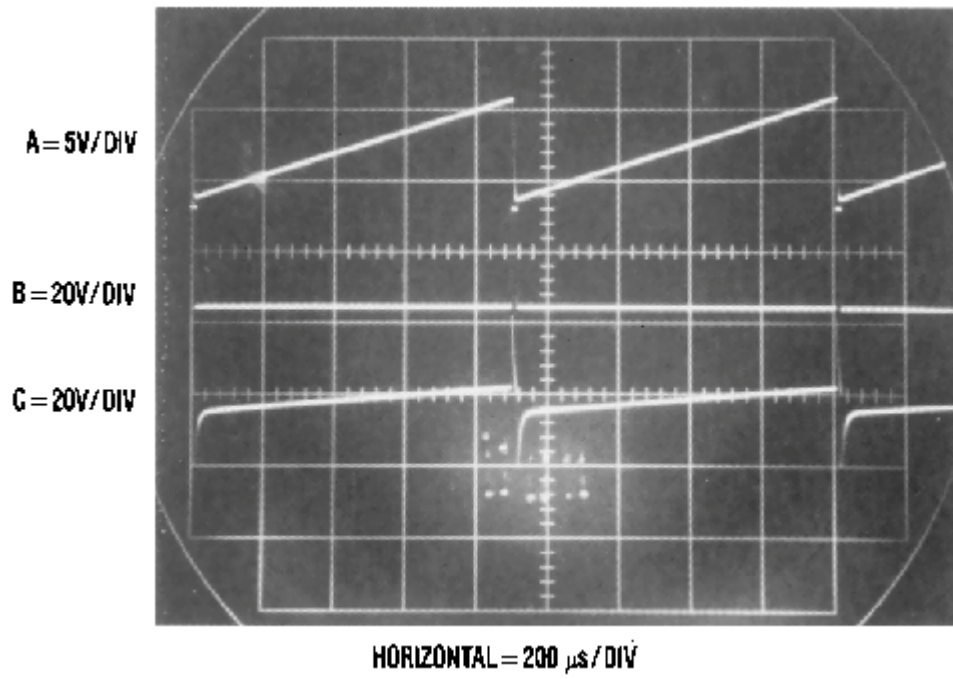

Figure 4. Output Traces

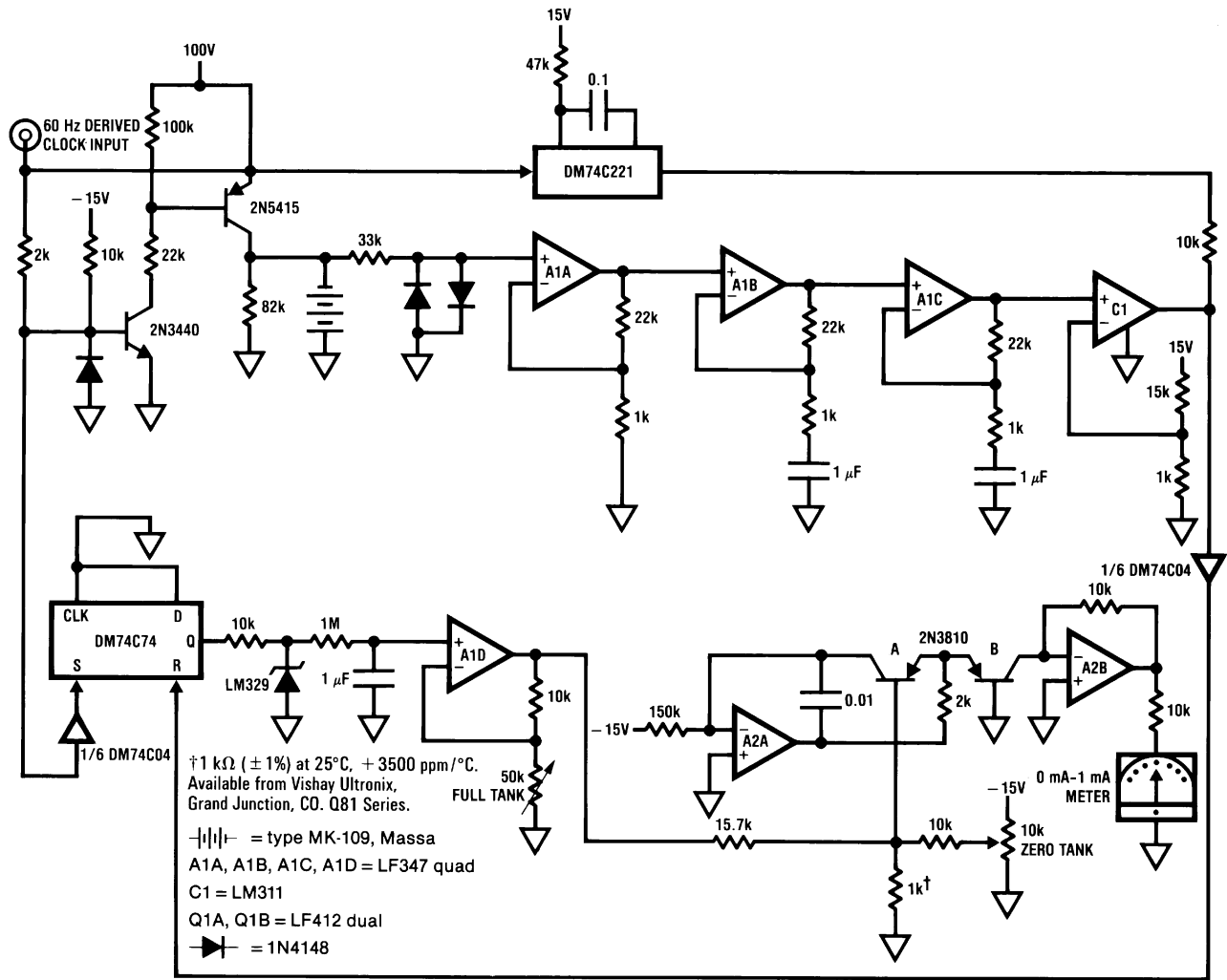

Figure 6. Exponentiator Circuit Used in a Non-Invasive, High Reliability Gas Gauge

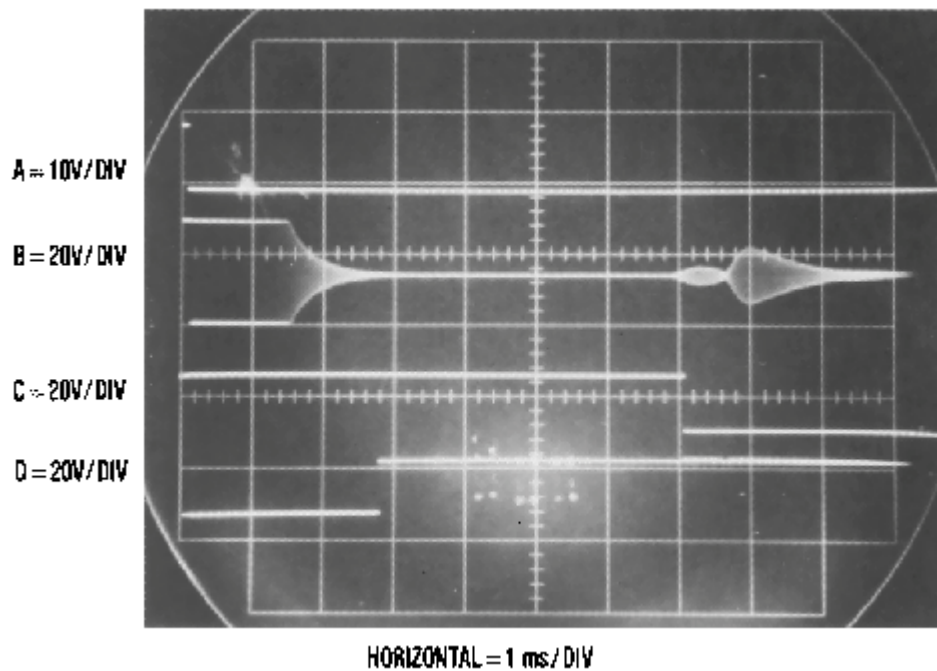
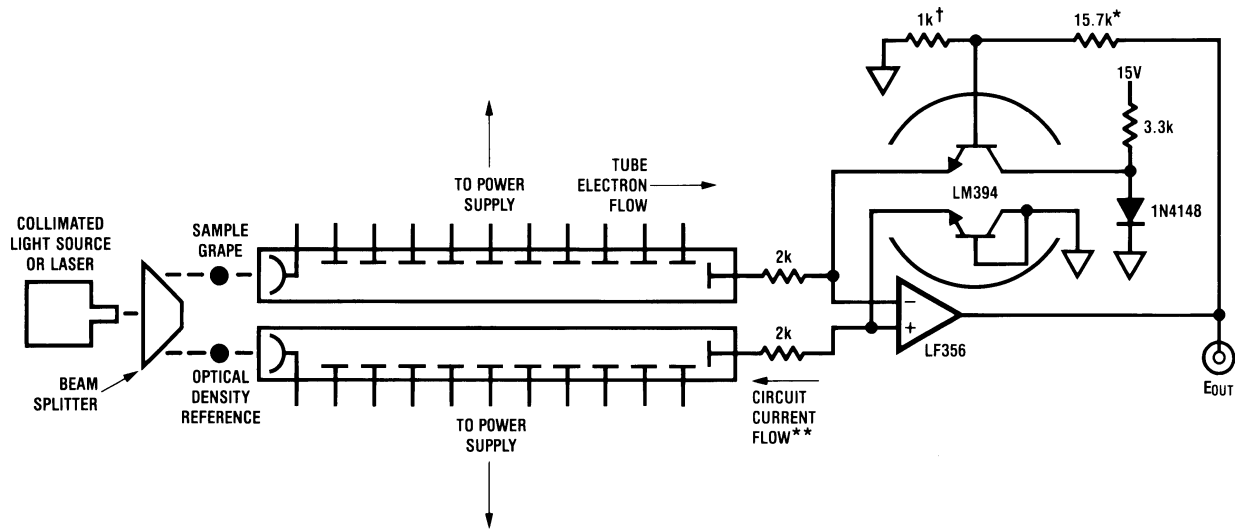

Figure 7. Output Traces

The last application determines density by using photometry. In this arrangement, a light source is optically split (Figure 8) and the resultant two beams drive light through a sample and an optical density reference. In this case, the optical sample is a grape, and the photometric set-up is used to correlate the optical density of the grape with its ripeness. Two photomultiplier tubes detect the light passed by the sample and the reference. The ratio of the photomultiplier outputs, which can vary over a wide range, is dependent upon the optical density difference of the sample and the reference. The tubes' output feed a log *ratio* amplifier. This configuration dispenses with the fixed current reference normally employed, and substitutes the output of the reference channel photomultiplier. In this fashion, the log amplifier's output represents the ratio between the densities of the sample and reference channels over a wide dynamic range. Variations in the light source intensity have no effect. Strictly speaking, the LF356 inputs are not at virtual ground, and an imperfect current-to-voltage conversion should result. In fact, the output impedance of the photomultipliers is so high that errors are minimal. The most significant log conformance error source in this simple log circuit is the fact that the transistor's collectors are at slightly different potentials. For the application shown, this uncertainty is not significant.



*1% film resistor†1 kΩ (±1%) at 25°C, +3500 ppm/°C.
 Available from Vishay Ultronix,
 Grand Junction, CO, Q81 Series.
 **≈ 10 μA nominal but may vary from
 10⁻⁴A to 10⁻⁹A

Figure 8. Optically Split Light Source

2 References

- *Non-Linear Circuits Handbook*, Analog Devices, Inc.
- *Logarithmic Converters*, Application Note AN-30

IMPORTANT NOTICE

Texas Instruments Incorporated and its subsidiaries (TI) reserve the right to make corrections, enhancements, improvements and other changes to its semiconductor products and services per JESD46, latest issue, and to discontinue any product or service per JESD48, latest issue. Buyers should obtain the latest relevant information before placing orders and should verify that such information is current and complete. All semiconductor products (also referred to herein as "components") are sold subject to TI's terms and conditions of sale supplied at the time of order acknowledgment.

TI warrants performance of its components to the specifications applicable at the time of sale, in accordance with the warranty in TI's terms and conditions of sale of semiconductor products. Testing and other quality control techniques are used to the extent TI deems necessary to support this warranty. Except where mandated by applicable law, testing of all parameters of each component is not necessarily performed.

TI assumes no liability for applications assistance or the design of Buyers' products. Buyers are responsible for their products and applications using TI components. To minimize the risks associated with Buyers' products and applications, Buyers should provide adequate design and operating safeguards.

TI does not warrant or represent that any license, either express or implied, is granted under any patent right, copyright, mask work right, or other intellectual property right relating to any combination, machine, or process in which TI components or services are used. Information published by TI regarding third-party products or services does not constitute a license to use such products or services or a warranty or endorsement thereof. Use of such information may require a license from a third party under the patents or other intellectual property of the third party, or a license from TI under the patents or other intellectual property of TI.

Reproduction of significant portions of TI information in TI data books or data sheets is permissible only if reproduction is without alteration and is accompanied by all associated warranties, conditions, limitations, and notices. TI is not responsible or liable for such altered documentation. Information of third parties may be subject to additional restrictions.

Resale of TI components or services with statements different from or beyond the parameters stated by TI for that component or service voids all express and any implied warranties for the associated TI component or service and is an unfair and deceptive business practice. TI is not responsible or liable for any such statements.

Buyer acknowledges and agrees that it is solely responsible for compliance with all legal, regulatory and safety-related requirements concerning its products, and any use of TI components in its applications, notwithstanding any applications-related information or support that may be provided by TI. Buyer represents and agrees that it has all the necessary expertise to create and implement safeguards which anticipate dangerous consequences of failures, monitor failures and their consequences, lessen the likelihood of failures that might cause harm and take appropriate remedial actions. Buyer will fully indemnify TI and its representatives against any damages arising out of the use of any TI components in safety-critical applications.

In some cases, TI components may be promoted specifically to facilitate safety-related applications. With such components, TI's goal is to help enable customers to design and create their own end-product solutions that meet applicable functional safety standards and requirements. Nonetheless, such components are subject to these terms.

No TI components are authorized for use in FDA Class III (or similar life-critical medical equipment) unless authorized officers of the parties have executed a special agreement specifically governing such use.

Only those TI components which TI has specifically designated as military grade or "enhanced plastic" are designed and intended for use in military/aerospace applications or environments. Buyer acknowledges and agrees that any military or aerospace use of TI components which have **not** been so designated is solely at the Buyer's risk, and that Buyer is solely responsible for compliance with all legal and regulatory requirements in connection with such use.

TI has specifically designated certain components as meeting ISO/TS16949 requirements, mainly for automotive use. In any case of use of non-designated products, TI will not be responsible for any failure to meet ISO/TS16949.

Products

Audio	www.ti.com/audio
Amplifiers	amplifier.ti.com
Data Converters	dataconverter.ti.com
DLP® Products	www.dlp.com
DSP	dsp.ti.com
Clocks and Timers	www.ti.com/clocks
Interface	interface.ti.com
Logic	logic.ti.com
Power Mgmt	power.ti.com
Microcontrollers	microcontroller.ti.com
RFID	www.ti-rfid.com
OMAP Applications Processors	www.ti.com/omap
Wireless Connectivity	www.ti.com/wirelessconnectivity

Applications

Automotive and Transportation	www.ti.com/automotive
Communications and Telecom	www.ti.com/communications
Computers and Peripherals	www.ti.com/computers
Consumer Electronics	www.ti.com/consumer-apps
Energy and Lighting	www.ti.com/energy
Industrial	www.ti.com/industrial
Medical	www.ti.com/medical
Security	www.ti.com/security
Space, Avionics and Defense	www.ti.com/space-avionics-defense
Video and Imaging	www.ti.com/video

TI E2E Community

e2e.ti.com