

# **Sine-Wave Oscillator**

*Ron Mancini and Richard Palmer*
*HPL (Dallas)*

## **ABSTRACT**

This note describes the operational amplifier (op-amp) sine-wave oscillator, together with the criteria for oscillation to occur using RC components. It delineates the roles of phase shift and gain in the circuit and then discusses considerations of the op amp. A brief analysis of a Wien-Bridge oscillator circuit is provided. Several examples of sine-wave oscillators are given, although it is recognized that there exist many additional types of oscillator to which the principles of this application note also apply.

## **Contents**

<b>1</b>	<b>Introduction</b> .....	<b>3</b>
<b>2</b>	<b>Sine-Wave Oscillator Defined</b> .....	<b>3</b>
<b>3</b>	<b>Requirements for Oscillation</b> .....	<b>3</b>
<b>4</b>	<b>Phase Shift in the Oscillator</b> .....	<b>5</b>
<b>5</b>	<b>Gain in the Oscillator</b> .....	<b>6</b>
<b>6</b>	<b>Effect of the Active Element (Op Amp) on the Oscillator</b> .....	<b>7</b>
<b>7</b>	<b>Analysis of Oscillator Operation (Circuit)</b> .....	<b>8</b>
<b>8</b>	<b>Sine-Wave Oscillator Circuits</b> .....	<b>10</b>
	8.1 Wein-Bridge Oscillator .....	10
	8.2 Phase-Shift Oscillator, Single Amplifier .....	14
	8.3 Phase-Shift Oscillator, Buffered .....	16
	8.4 Bubba Oscillator .....	17
	8.5 Quadrature Oscillator .....	18
<b>9</b>	<b>Conclusion</b> .....	<b>19</b>
<b>10</b>	<b>References</b> .....	<b>20</b>

## **List of Figures**

1	Canonical Form of a System With Positive or Negative Feedback .....	4
2	Phase Plot of RC Sections .....	5
3	Op-Amp Frequency Response .....	7
4	Distortion vs Oscillation Frequency for Various Op-Amp Bandwidths .....	8
5	Block Diagram of an Oscillator .....	9
6	Amplifier With Positive and Negative Feedback .....	9
7	Wein-Bridge Circuit Schematic .....	10

Trademarks are the property of their respective owners.

8	Final Wein-Bridge Oscillator Circuit	11
9	Wein-Bridge Output Waveforms: Effects of RF on Distortion	12
10	Wein-Bridge Oscillator With Nonlinear Feedback	12
11	Output of the Circuit in Figure 10	13
12	Wein-Bridge Oscillator With AGC	14
13	Output of the Circuit in Figure 12	14
14	Phase-Shift Oscillator (Single Op Amp)	15
15	Output of the Circuit in Figure 14	15
16	Phase-Shift Oscillator, Buffered	16
17	Output of the Circuit Figure 16	16
18	Bubba Oscillator	17
19	Output of the Circuit in Figure 18	18
20	Quadrature Oscillator	19
21	Output of the Circuit in Figure 20	19

## 1 Introduction

Oscillators are circuits that produce specific, periodic waveforms such as square, triangular, sawtooth, and sinusoidal. They generally use some form of active device, lamp, or crystal, surrounded by passive devices such as resistors, capacitors, and inductors, to generate the output.

There are two main classes of oscillator: relaxation and sinusoidal. Relaxation oscillators generate the triangular, sawtooth and other nonsinusoidal waveforms and are not discussed in this note. Sinusoidal oscillators consist of amplifiers with external components used to generate oscillation, or crystals that internally generate the oscillation. The focus here is on sine wave oscillators, created using operational amplifiers op amps.

Sine wave oscillators are used as references or test waveforms by many circuits. A pure sine wave has only a single or fundamental frequency—ideally no harmonics are present. Thus, a sine wave may be the input to a device or circuit, with the output harmonics measured to determine the amount of distortion. The waveforms in relaxation oscillators are generated from sine waves that are summed to provide a specified shape.

## 2 Sine-Wave Oscillator Defined

Op-amp oscillators are circuits that are unstable—not the type that are sometimes unintentionally designed or created in the lab—but ones that are intentionally designed to remain in an unstable or oscillatory state. Oscillators are useful for generating uniform signals that are used as a reference in such applications as audio, function generators, digital systems, and communication systems.

Two general classes of oscillators exist: sinusoidal and relaxation. Sinusoidal oscillators consist of amplifiers with RC or LC circuits that have adjustable oscillation frequencies, or crystals that have a fixed oscillation frequency. Relaxation oscillators generate triangular, sawtooth, square, pulse, or exponential waveforms, and they are not discussed here.

Op-amp sine-wave oscillators operate without an externally-applied input signal. Instead, some combination of positive and negative feedback is used to drive the op amp into an unstable state, causing the output to cycle back and forth between the supply rails at a continuous rate. The frequency and amplitude of oscillation are set by the arrangement of passive and active components around a central op amp.

Op-amp oscillators are restricted to the lower end of the frequency spectrum because op amps do not have the required bandwidth to achieve low phase shift at high frequencies. Voltage-feedback op amps are limited to a low kHz range because their dominant, open-loop pole may be as low as 10 Hz. The new current-feedback op amps have a much wider bandwidth, but they are very hard to use in oscillator circuits because they are sensitive to feedback capacitance. Crystal oscillators are used in high-frequency applications up to the hundreds of MHz range.

## 3 Requirements for Oscillation

The canonical, or simplest, form of a negative feedback system is used to demonstrate the requirements for oscillation to occur. Figure 1 shows the block diagram for this system in which  $V_{IN}$  is the input voltage,  $V_{OUT}$  is the output voltage from the amplifier gain block (A), and  $\beta$  is the signal, called the feedback factor, that is fed back to the summing junction. E represents the error term that is equal to the summation of the feedback factor and the input voltage.

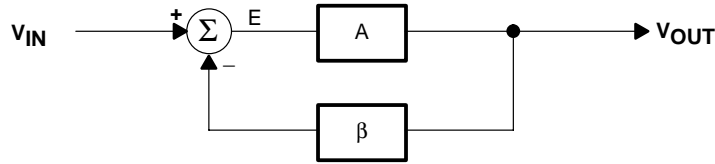

**Figure 1. Canonical Form of a Feedback System With Positive or Negative Feedback**

The corresponding classic expression for a feedback system is derived as follows. Equation 1 is the defining equation for the output voltage; equation 2 is the corresponding error:

$$V_{\text{OUT}} = E \times A \quad (1)$$

$$E = V_{\text{IN}} + \beta V_{\text{OUT}} \quad (2)$$

Eliminating the error term, E, from these equations gives

$$\frac{V_{\text{OUT}}}{A} = V_{\text{IN}} - \beta V_{\text{OUT}} \quad (3)$$

and collecting the terms in  $V_{\text{OUT}}$  yields

$$V_{\text{IN}} = V_{\text{OUT}} \left( \frac{1}{A} + \beta \right) \quad (4)$$

Rearrangement of the terms produces equation 5, the classical form of feedback expression:

$$\frac{V_{\text{OUT}}}{V_{\text{IN}}} = \frac{A}{1 + A\beta} \quad (5)$$

Oscillators do not require an externally-applied input signal; instead, they use some fraction of the output signal created by the feedback network as the input signal.

Oscillation results when the feedback system is not able to find a stable steady-state because its transfer function can not be satisfied. The system goes unstable when the denominator in equation 5 becomes zero, i.e., when  $1 + A\beta = 0$ , or  $A\beta = -1$ . The key to designing an oscillator is ensuring that  $A\beta = -1$ . This is called the *Barkhausen criterion*. Satisfying this criterion requires that the magnitude of the loop gain is unity with a corresponding phase shift of  $180^\circ$  as indicated by the minus sign. An equivalent expression using the symbology of complex algebra is  $A\beta = 1 \angle -180^\circ$  for a negative feedback system. For a positive feedback system, the expression is  $A\beta = 1 \angle 0^\circ$  and the sign of the  $A\beta$  term is negative in equation 5.

As the phase shift approaches  $180^\circ$  and  $|A\beta| \rightarrow 1$ , the output voltage of the now-unstable system tends to infinity but, of course, is limited to finite values by an energy-limited power supply. When the output voltage approaches either power rail, the active devices in the amplifiers change gain. This causes the value of A to change and forces  $A\beta$  away from the singularity; thus the trajectory towards an infinite voltage slows and eventually halts. At this stage, one of three things can occur: (i) Nonlinearity in saturation or cutoff causes the system to become stable and lock up at the current power rail. (ii) The initial change causes the system to saturate (or cutoff) and stay that way for a long time before it becomes linear and heads for the opposite power rail. (iii) The system stays linear and reverses direction, heading for the opposite power rail. The second alternative produces highly distorted oscillations (usually quasi-square waves), the resulting oscillators being called relaxation oscillators. The third produces a sine-wave oscillator.

## 4 Phase Shift in the Oscillator

The  $180^\circ$  phase shift in the equation  $A\beta = 1 \angle -180^\circ$  is introduced by active and passive components. Like any well-designed feedback circuit, oscillators are made dependent on passive-component phase shift because it is accurate and almost drift-free. The phase shift contributed by active components is minimized because it varies with temperature, has a wide initial tolerance, and is device dependent. Amplifiers are selected so that they contribute little or no phase shift at the oscillation frequency. These constraints limit the op-amp oscillator to relatively low frequencies.

A single-pole RL or RC circuit contributes up to  $90^\circ$  phase shift per pole, and because  $180^\circ$  of phase shift is required for oscillation, at least two poles must be used in the oscillator design. An LC circuit has two poles, thus it contributes up to  $180^\circ$  phase shift per pole pair. But LC and LR oscillators are not considered here because low frequency inductors are expensive, heavy, bulky, and highly nonideal. LC oscillators are designed in high frequency applications, beyond the frequency range of voltage feedback op amps, where the inductor size, weight, and cost are less significant. Multiple RC sections are used in low frequency oscillator design in lieu of inductors.

Phase shift determines the oscillation frequency because the circuit oscillates at whatever frequency accumulates a  $180^\circ$  phase shift. The sensitivity of phase to frequency,  $d\phi/d\omega$ , determines the frequency stability. When buffered RC sections (an op amp buffer provides high input and low output impedance) are cascaded, the phase shift multiplies by the number of sections,  $n$  (see Figure 2).

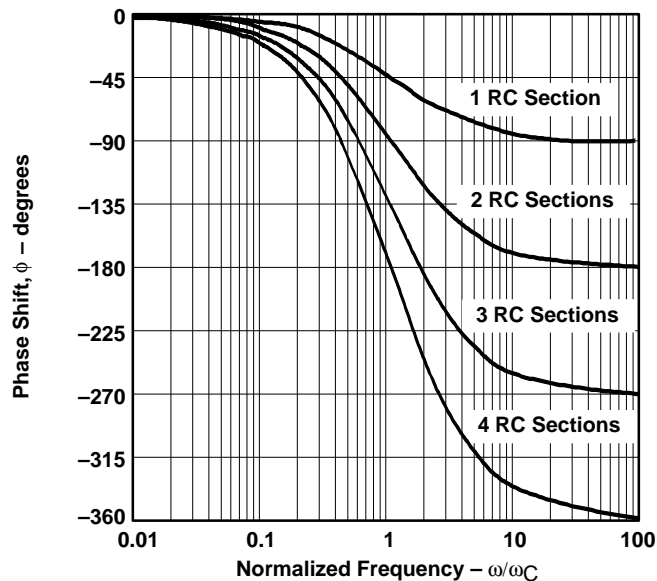

Figure 2. Phase Plot of RC Sections

In the region where the phase shift is  $180^\circ$ , the frequency of oscillation is very sensitive to the phase shift. Thus, a tight frequency specification requires that the phase shift,  $d\phi$ , be kept within exceedingly narrow limits for there to be only small variations in frequency,  $d\omega$ , at  $180^\circ$ . Figure 2 demonstrates that, although two cascaded RC sections eventually provide  $180^\circ$  phase shift, the value of  $d\phi/d\omega$  at the oscillator frequency is unacceptably small. Thus, oscillators made with two cascaded RC sections have poor frequency stability. Three equal cascaded RC filter sections

have a much higher  $d\phi/d\omega$  (see Figure 2), and the resulting oscillator has improved frequency stability. Adding a fourth RC section produces an oscillator with an excellent  $d\phi/d\omega$  (see Figure 2); thus, this is the most stable RC oscillator configuration. Four sections are the maximum number used because op amps come in quad packages, and the four-section oscillator yields four sine waves  $45^\circ$  phase shifted relative to each other. This oscillator can be used to obtain sine/cosine or quadrature sine waves.

Crystal or ceramic resonators make the most stable oscillators because resonators have an extremely high  $d\phi/d\omega$  as a result of their nonlinear properties. Resonators are used for high-frequency oscillators, but low-frequency oscillators do not use resonators because of size, weight, and cost restrictions. Op amps are not generally used with crystal or ceramic resonator oscillators because op amps have low bandwidth. Experience shows that rather than using a low-frequency resonator for low frequencies, it is more cost effective to build a high frequency crystal oscillator, count the output down, and then filter the output to obtain the low frequency.

## 5 Gain in the Oscillator

The oscillator gain must be unity ( $A\beta = 1 \angle -180^\circ$ ) at the oscillation frequency. Under normal conditions, the circuit becomes stable when the gain exceeds unity, and oscillations cease. However, when the gain exceeds unity with a phase shift of  $-180^\circ$ , the nonlinearity of the active device reduces the gain to unity and the circuit oscillates. The nonlinearity becomes significant when the amplifier swings close to either power rail because cutoff or saturation reduces the active device (transistor) gain. The paradox is that worst-case design practice requires nominal gains exceeding unity for manufacturability, but excess gain causes increased distortion of the output sine wave.

When the gain is too low, oscillations cease under worst case conditions, and when the gain is too high, the output wave form looks more like a square wave than a sine wave. Distortion is a direct result of excessive gain overdriving the amplifier; thus, gain must be carefully controlled in low-distortion oscillators. Phase-shift oscillators have distortion, but they achieve low-distortion output voltages because cascaded RC sections act as distortion filters. Also, buffered phase-shift oscillators have low distortion because the gain is controlled and distributed among the buffers.

Most circuit configurations require an auxiliary circuit for gain adjustment when low-distortion outputs are desired. Auxiliary circuits range from inserting a nonlinear component in the feedback loop, to automatic gain control (AGC) loops, to limiting by external components such as resistors and diodes. Consideration must also be given to the change in gain resulting from temperature variations and component tolerances, and the level of circuit complexity is determined based on the required stability of the gain. The more stable the gain, the better the purity of the sine wave output.

## 6 Effect of the Active Element (Op Amp) on the Oscillator

Until now, it has been assumed that the op amp has infinite bandwidth and the output is frequency independent. In reality, the op amp has many poles, but it has been compensated so that they are dominated by a single pole over the specified bandwidth. Thus,  $A\beta$  must now be considered frequency dependent via the op-amp gain term,  $A$ . Equation 6 shows this dependence, where  $a$  is the maximum open loop gain,  $\omega_a$  is the dominant pole frequency, and  $\omega$  is the frequency of the signal. Figure 3 depicts the frequency dependence of the op-amp gain and phase. The closed-loop gain,  $A_{CL} = 1/\beta$ , does not contain any poles or zeros and is, therefore, constant with frequency to the point where it affects the op-amp open-loop gain at  $\omega_{3dB}$ . Here, the signal amplitude is attenuated by 3 dB and the phase shift introduced by the op amp is  $45^\circ$ . The amplitude and phase really begin to change one decade below this point, at  $0.1 \times \omega_{3dB}$ , and the phase continues to shift until it reaches  $90^\circ$  at  $10 \omega_{dB}$ , one decade beyond the 3-dB point. The gain continues to roll off at  $-20$  dB/decade until other poles and zeros come into play. The higher the closed-loop gain,  $A_{CL}$ , the earlier it intercepts the op-amp gain.

$$A = \frac{a}{1 + j\frac{\omega}{\omega_a}} \quad (6)$$

The phase shift contributed by the op amp affects the performance of the oscillator circuit by lowering the oscillation frequency, and the reduction in  $A_{CL}$  can make  $A\beta < 1$  and the oscillator then ceases to oscillate.

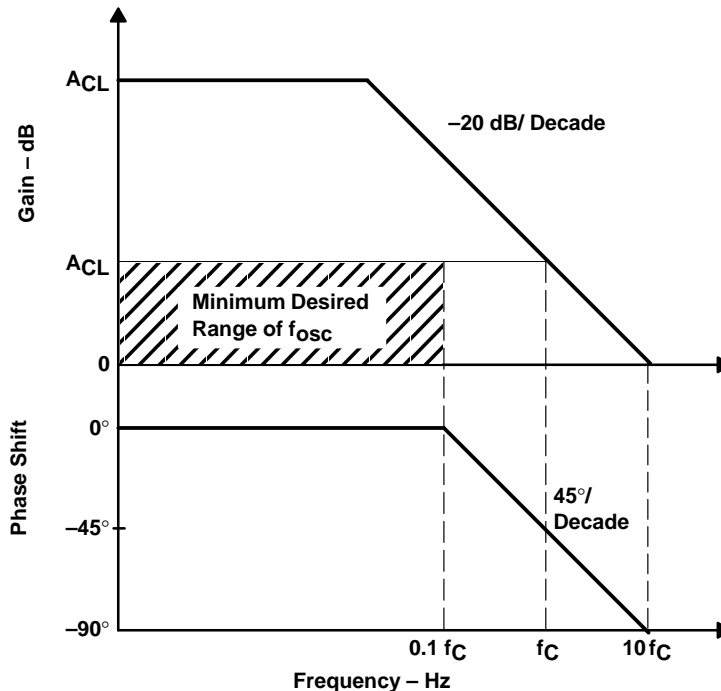
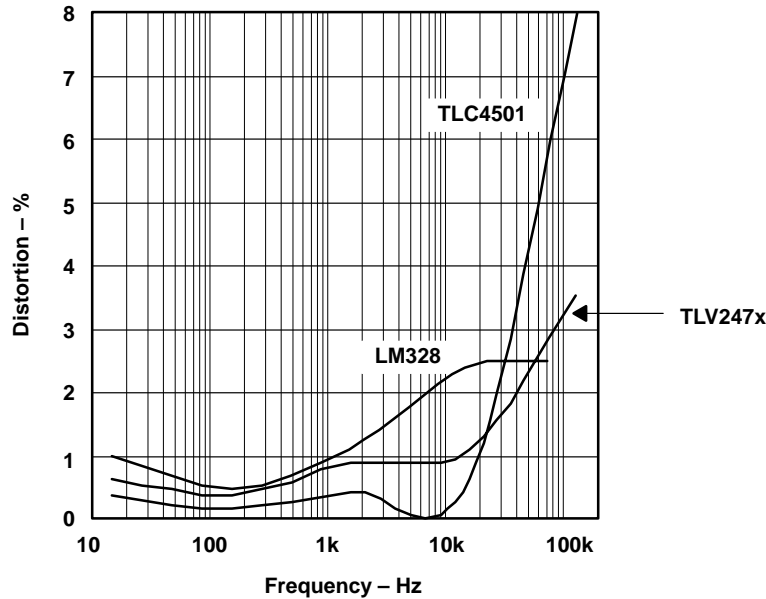

Figure 3. Op-Amp Frequency Response

Most op amps are compensated and may have more than the  $45^\circ$  of phase shift at the  $\omega_{3dB}$  point. Therefore, the op amp should be chosen with a gain bandwidth at least one decade above the oscillation frequency, as shown by the shaded area of Figure 3. The Wien bridge requires a gain bandwidth greater than  $43 \omega_{OSC}$  to maintain the gain and frequency within 10% of the ideal

values [2]. Figure 4 compares the output distortion vs frequency curves of an LM328, a TLV247x, and a TLC071 op amp, which have bandwidths of 0.4 MHz, 2.8 MHz, and 10 MHz, respectively, in a Wein bridge oscillator circuit with nonlinear feedback (see section 7.1 for the circuit and transfer function). The oscillation frequency ranges from 16 Hz to 160 kHz. The graph illustrates the importance of choosing the correct op amp for the application. The LM328 achieves a maximum oscillation of 72 kHz and is attenuated more than 75%, while the TLV247x achieves 125 kHz with 18% attenuation. The wide bandwidth of the TLC071 provides a 138 kHz oscillation frequency with a mere 2% attenuation. The op amp must be chosen with the correct bandwidth or else the output will oscillate at a frequency well below the design specification.



**Figure 4. Distortion vs Oscillation Frequency for Various Op-Amp Bandwidths**

Care must be taken when using large feedback resistors because they interact with the input capacitance of the op amp to create poles with negative feedback, and both poles and zeros with positive feedback. Large resistor values can move these poles and zeros into the neighborhood of the oscillation frequency and affect the phase shift [3].

Final consideration is given to the op amp's slew-rate limitation. The slew rate must be greater than  $2\pi V_P f_0$ , where  $V_P$  is the peak output voltage and  $f_0$  is the oscillation frequency; otherwise, distortion of the output signal results.

## 7 Analysis of Oscillator Operation (Circuit)

Oscillators are created using various combinations of positive and negative feedback. Figure 5a shows the basic negative feedback amplifier block diagram with a positive feedback loop added. When positive and negative feedback are used, the gain of the negative feedback path is combined into a single gain term (representing closed-loop gain). Figure 5a reduces to Figure 5b, the positive feedback network is then represented by  $\beta = \beta_2$ , and subsequent analysis is simplified. When negative feedback is used, the positive-feedback loop can be ignored because  $\beta_2$  is zero.





Figure 5. Block Diagram of an Oscillator

The general form of an op amp with positive and negative feedback is shown in Figure 6 (a). The first step in analysis is to break the loop at some point without altering the gain of the circuit. The positive feedback loop is broken at the point marked with an X. A test signal ( $V_{TEST}$ ) is applied to the broken loop and the resulting output voltage ( $V_{OUT}$ ) is measured with the equivalent circuit shown in Figure 6 (b).

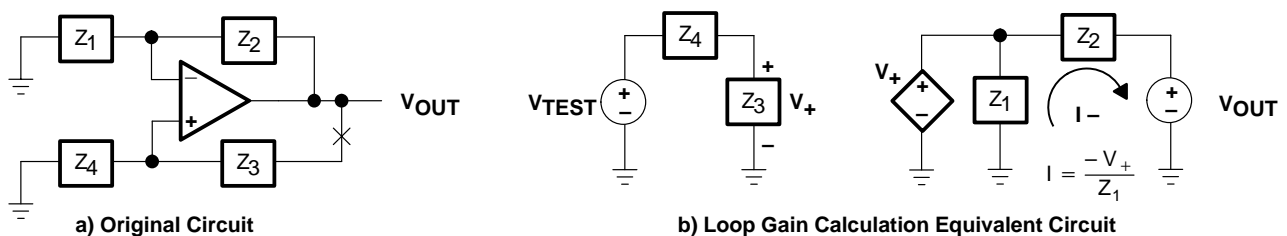

Figure 6. Amplifier With Positive and Negative Feedback

First,  $V_+$  is calculated using equation 7; then it is treated as an input signal to a noninverting amplifier, resulting in equation 8. Substituting equation 7 for  $V_+$  in equation 8 gives the transfer function in equation 9. The actual circuit elements are then substituted for each impedance and the equation is simplified. These equations are valid when the op-amp open-loop gain is large and the oscillation frequency is less than  $0.1 \omega_{3dB}$ .

$$V_+ = V_{TEST} \left( \frac{Z_3}{Z_3 + Z_4} \right) \quad (7)$$

$$V_{OUT} = V_+ \left( \frac{Z_1 + Z_2}{Z_1} \right) \quad (8)$$

$$\frac{V_{OUT}}{V_{TEST}} = \left( \frac{Z_3}{Z_3 + Z_4} \right) \left( \frac{Z_1 + Z_2}{Z_1} \right) \quad (9)$$

Phase-shift oscillators generally use negative feedback, so the positive feedback factor ( $\beta_2$ ) becomes zero. Oscillator circuits such as the Wien bridge use both negative ( $\beta_1$ ) and positive ( $\beta_2$ ) feedback to achieve a constant state of oscillation. Equation 9 is used to analyze this circuit in detail in section 8.1.

## 8 Sine Wave Oscillator Circuits

There are many types of sine wave oscillator circuits and variants—in an application, the choice depends on the frequency and the desired monotonicity of the output waveform. The focus of this section is on the more prominent oscillator circuits: Wien bridge, phase shift, and quadrature. The transfer function is derived for each case using the techniques described in section 6 of this note and in references 4, 5, and 6.

### 8.1 Wein Bridge Oscillator

The Wien bridge is one of the simplest and best known oscillators and is used extensively in circuits for audio applications. Figure 7 shows the basic Wien bridge circuit configuration. On the positive side, this circuit has only a few components and good frequency stability. The major drawback of the circuit is that the output amplitude is at the rails, which saturates the op-amp output transistors and causes high output distortion. Taming this distortion is more challenging than getting the circuit to oscillate. There are a couple of ways to minimize this effect. These will be covered later; first the circuit is analyzed to obtain the transfer function.

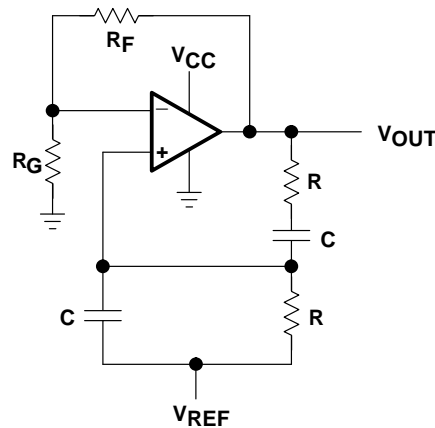

**Figure 7. Wein-Bridge Circuit Schematic**

The Wien bridge circuit has the form already detailed in section 6, and the transfer function for the circuit is derived using the technique described there. It is readily apparent that  $Z_1 = R_G$ ,  $Z_2 = R_F$ ,  $Z_3 = (R_1 + 1/sC_1)$  and  $Z_4 = (R_2 || 1/sC_2)$ . The loop is broken between the output and  $Z_1$ ,  $V_{TEST}$  is applied to  $Z_1$ , and  $V_{OUT}$  is calculated. The positive feedback voltage,  $V_+$ , is calculated first in equations 10 through 12. Equation 10 shows the simple voltage divider at the noninverting input. Each term is then multiplied by  $(R_2C_2s + 1)$  and divided by  $R_2$  to get equation 11.

$$V_+ = V_{TEST} \left( \frac{Z_2}{Z_3 + Z_4} \right) = V_{TEST} \left[ \frac{\left( \frac{R_2}{R_2C_2s + 1} \right)}{\left( \frac{R_2}{R_2C_2s + 1} \right) + \left( R_1 + \frac{1}{C_1s} \right)} \right] \quad (10)$$

$$\frac{V_+}{V_{TEST}} = \frac{1}{1 + R_1C_2s + \frac{R_1}{R_2} + \frac{1}{R_2C_1s} + \frac{C_2}{C_1}} \quad (11)$$

Substituting  $s = j\omega_0$ , where  $\omega_0$  is the oscillation frequency,  $\omega_1 = 1/R_1C_2$ , and  $\omega_2 = 1/R_2C_1$ , gives equation 12.

$$\frac{V_+}{V_{\text{TEST}}} = \frac{1}{1 + \frac{R_1}{R_2} + \frac{C_2}{C_1} + j \left( \frac{\omega_0}{\omega_1} - \frac{\omega_2}{\omega_0} \right)} \quad (12)$$

Some interesting relationships now become apparent. The capacitor at the zero, represented by  $\omega_1$ , and the capacitor at the pole, represented by  $\omega_2$ , must each contribute  $90^\circ$  of phase shift toward the  $180^\circ$  required for oscillation at  $\omega_0$ . This requires that  $C_1 = C_2$  and  $R_1 = R_2$ . Setting  $\omega_1$  and  $\omega_2$  equal to  $\omega_0$  cancels the frequency terms, ideally removing any change in amplitude with frequency because the pole and zero negate one another. This results in an overall feedback factor of  $\beta = 1/3$  (equation 13).

$$\frac{V_+}{V_{\text{TEST}}} = \frac{1}{1 + \frac{R}{R} + \frac{C}{C} + j \left( \frac{\omega_0}{\omega} - \frac{\omega}{\omega_0} \right)} = \frac{1}{3 + j \left( \frac{\omega_0}{\omega} - \frac{\omega}{\omega_0} \right)} = \frac{1}{3} \quad (13)$$

The gain,  $A$ , of the negative feedback portion of the circuit must then be set such that  $|A\beta| = 1$ , requiring  $A = 3$ .  $R_F$  must be set to twice the value of  $R_G$  to satisfy this condition. The op amp in Figure 7 is single supply, so a dc reference voltage,  $V_{\text{REF}}$ , must be applied to bias the output for full-scale swing and minimal distortion. Applying  $V_{\text{REF}}$  to the positive input through  $R_2$  restricts dc current flow to the negative feedback leg of the circuit.  $V_{\text{REF}}$  was set at 0.833V to bias the output at the midrail of the single supply, rail-to-rail input and output amplifier, or 2.5 V. (see reference [7].  $V_{\text{REF}}$  is shorted to ground for split supply applications.

The final circuit is shown in Figure 8, with component values selected to provide an oscillation frequency of  $\omega_0 = 2\pi f_0$ , where  $f_0 = 1/(2\pi RC) = 1.59$  kHz. The circuit oscillated at 1.57 kHz, caused by varying component values with 2.8% distortion. This high value results from the extensive clipping of the output signal at both supply rails, producing several large odd and even harmonics. The feedback resistor was then adjusted  $\pm 1\%$ . Figure 9 shows the output voltage waveforms. The distortion grew as the saturation increased with increasing  $R_F$ , and oscillations ceased when  $R_F$  was decreased by a mere 0.8%.

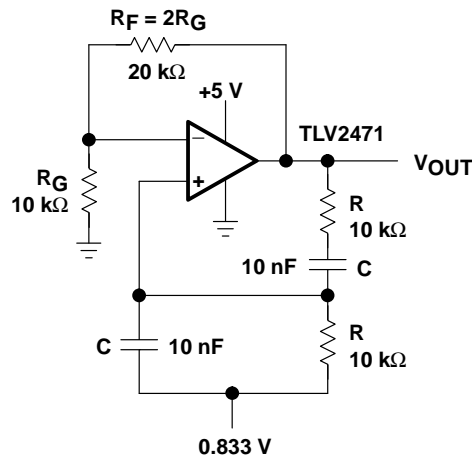
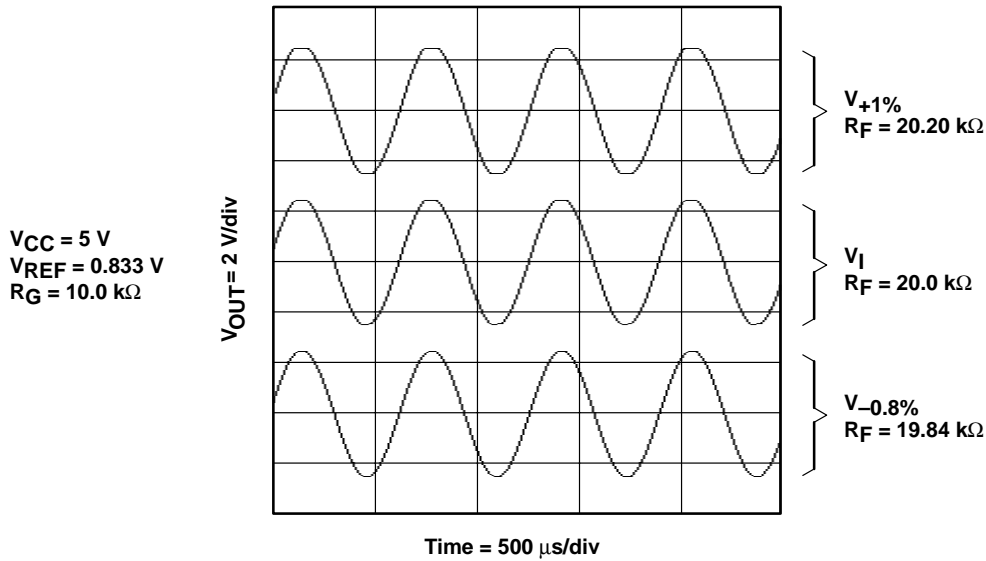
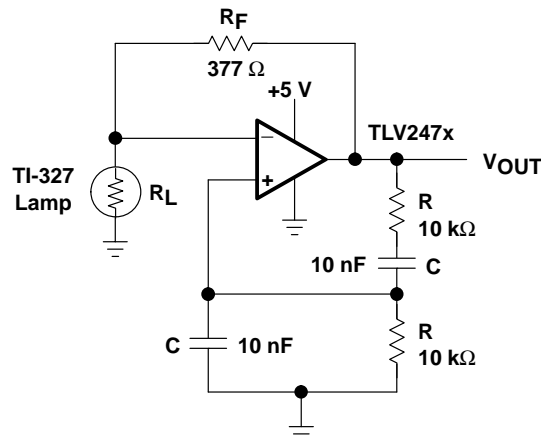

Figure 8. Final Wein-Bridge Oscillator Circuit

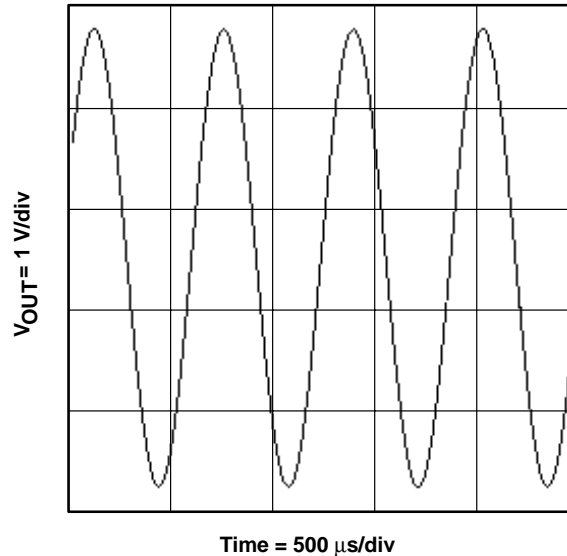

**Figure 9. Wein-Bridge Output Waveforms: Effects of  $R_F$  on Distortion**

Applying nonlinear feedback can minimize the distortion inherent in the basic Wien bridge circuit. A nonlinear component such as an incandescent lamp can be substituted into the circuit for  $R_G$  as shown in Figure 10. The lamp resistance,  $R_{LAMP}$ , is nominally selected at one half the feedback resistance,  $R_F$ , at the lamp current established by  $R_F$  and  $R_{LAMP}$ . When the power is first applied the lamp is cool and its resistance is small, so the gain is large ( $> 3$ ). The current heats up the filament and the resistance increases, lowering the gain. The nonlinear relationship between the lamp current and resistance keeps output voltage changes small—a small change in voltage means a large change in resistance. Figure 11 shows the output of this amplifier with a distortion of less than 0.1% for  $f_{OSC} = 1.57\text{ kHz}$ . The distortion for this variation is greatly reduced over the basic circuit by avoiding hard saturation of the op amp transistors.



**Figure 10. Wein-Bridge Oscillator With Nonlinear Feedback**



**Figure 11. Output of the Circuit in Figure 10**

The impedance of the lamp is mostly caused by thermal effects. The output amplitude is very temperature sensitive and tends to drift. The gain must then be set higher than 3 to compensate for any temperature variations, and this increases the distortion in the circuit [4]. This type of circuit is useful when the temperature does not fluctuate over a wide range or when used in conjunction with an amplitude-limiting circuit.

The lamp has an effective low-frequency thermal time constant,  $t_{\text{thermal}}$  [5]. As  $f_{\text{OSC}}$  approaches  $t_{\text{thermal}}$ , distortion greatly increases. Several lamps can be placed in series to increase  $t_{\text{thermal}}$  and reduce distortion. The drawbacks are that the time required for oscillations to stabilize increases and the output amplitude reduces.

An automatic gain-control (AGC) circuit must be used when neither of the two previous circuits yields low enough distortion. A typical Wien bridge oscillator with an AGC circuit is shown in Figure 12; Figure 13 shows the output waveform of the circuit. The AGC is used to stabilize the magnitude of the sinusoidal output to an optimum gain level. The JFET serves as the AGC element, providing excellent control because of the wide range of the drain-to-source resistance, which is controlled by the gate voltage. The JFET gate voltage is zero when the power is applied, and thus turns on with a low drain-to-source resistance ( $R_{\text{DS}}$ ). This places  $R_{\text{G2}}+R_{\text{S}}+R_{\text{DS}}$  in parallel with  $R_{\text{G1}}$ , raising the gain to 3.05, and oscillations begin, gradually building up. As the output voltage grows, the negative swing turns the diode on and the sample is stored on  $C_1$ , providing a dc potential to the gate of  $Q_1$ . Resistor  $R_1$  limits the current and establishes the time constant for charging  $C_1$  (which should be much greater than  $f_{\text{OSC}}$ ). When the output voltage drifts high,  $R_{\text{DS}}$  increases, lowering the gain to a minimum of 2.87 ( $1+R_{\text{F}}/R_{\text{G1}}$ ). The output stabilizes when the gain reaches 3. The distortion of the AGC is less than 0.2%.

The circuit of Figure 12 is biased with  $V_{\text{REF}}$  for a single-supply amplifier. A zener diode can be placed in series with D1 to limit the positive swing of the output and reduce distortion. A split supply can be easily implemented by grounding all points connected to  $V_{\text{REF}}$ . There is a wide variety of Wien bridge variants to control the amplitude more precisely and allow selectable or even variable oscillation frequencies. Some circuits use diode limiting in place of a nonlinear feedback component. Diodes reduce distortion by providing a soft limit for the output voltage.

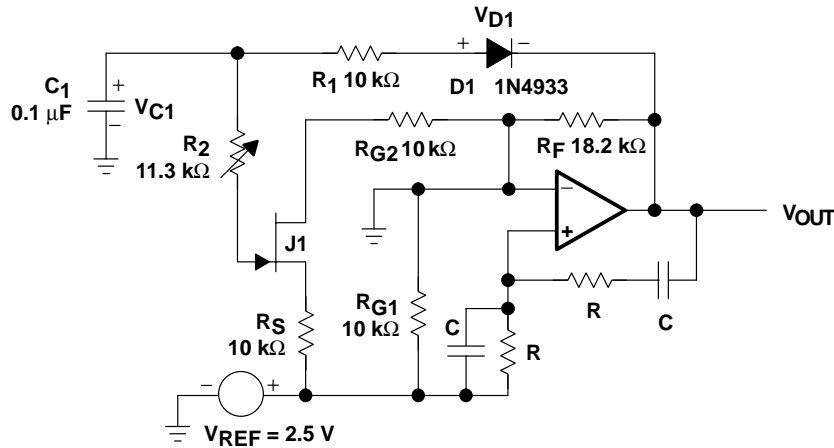

**Figure 12. Wein-Bridge Oscillator With AGC**

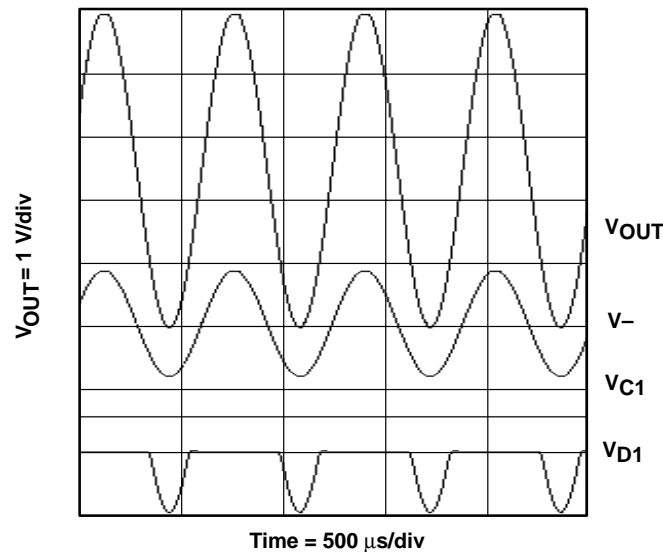

**Figure 13. Output of the Circuit in Figure 12**

## 8.2 Phase-Shift Oscillator, Single Amplifier

Phase-shift oscillators have less distortion than the Wien bridge oscillator, coupled with good frequency stability. A phase-shift oscillator can be built with one op amp as shown in Figure 14. Three RC sections are cascaded to get the steep slope,  $d\phi/d\omega$ , required for a stable oscillation frequency, as described in section 3. Fewer RC sections results in high oscillation frequency and interference with the op-amp BW limitations.

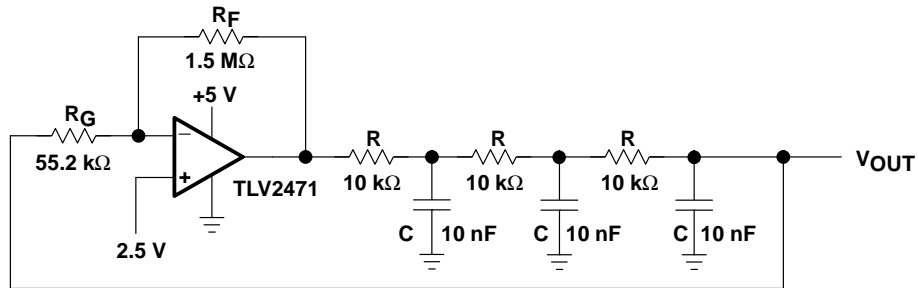

Figure 14. Phase-Shift Oscillator (Single Op Amp)

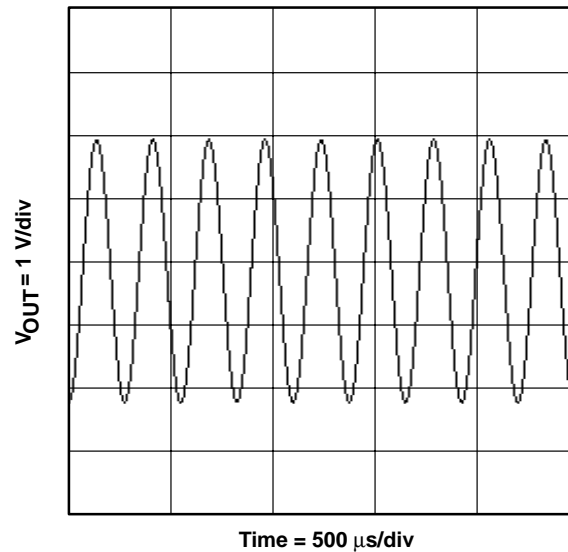

Figure 15. Output of the Circuit in Figure 14

The usual assumption is that the phase shift sections are independent of each other, allowing equation 14 to be written. The loop phase shift is  $-180^\circ$  when the phase shift of each section is  $-60^\circ$ . This occurs when  $\omega = 2\pi f = 1.732/RC$  ( $\tan 60^\circ = 1.732\dots$ ). The magnitude of  $\beta$  at this point is  $(1/2)^3$ , so the gain,  $A$ , must be 8 for the system gain of unity.

$$A\beta = A\left(\frac{1}{RCs + 1}\right)^3 \quad (14)$$

The oscillation frequency with the component values shown in Figure 14 is 3.76 kHz rather than the calculated oscillation frequency of 2.76 kHz. Also, the gain required to start oscillation is 27 rather than the calculated gain of 8. These discrepancies are partially due to component variations, however, the biggest factor is the incorrect assumption that the RC sections do not load each other. This circuit configuration was very popular when active components were large and expensive. But now op amps are inexpensive, small, and come four-to-a-package, so the single-op-amp phase-shift oscillator is losing popularity. The output distortion is a low 0.46%, considerably less than the Wien bridge circuit without amplitude stabilization.

### 8.3 Phase-Shift Oscillator, Buffered

The buffered phase-shift oscillator is much improved over the unbuffered version, the penalty being a higher component count. Figures 16 and 17 show the buffered phase-shift oscillator and the resulting output waveform, respectively. The buffers prevent the RC sections from loading each other, hence the buffered phase-shift oscillator performs more nearly at the calculated frequency and gain. The gain-setting resistor,  $R_G$ , loads the third RC section. If the fourth buffer in a quad op amp buffers this RC section, the performance becomes ideal. Low-distortion sine waves can be obtained from either phase-shift oscillator design, but the purest sine wave is taken from the output of the last RC section. This is a high-impedance node, so a high impedance input is mandated to prevent loading and frequency shifting with load variations.

The circuit oscillated at 2.9 kHz compared to an ideal frequency of 2.76 kHz, and it oscillated with a gain of 8.33 compared to an ideal gain of 8. The distortion was 1.2%, considerably more than the unbuffered phase-shift oscillator. The discrepancies and higher distortion are due to the large feedback resistor,  $R_F$ , which created a pole with  $C_{IN}$  of approximately 5 kHz. Resistor  $R_G$  still loaded down the last RC section. Adding a buffer between the last RC section and  $V_{OUT}$  lowered the gain and the oscillation frequency to the calculated values.

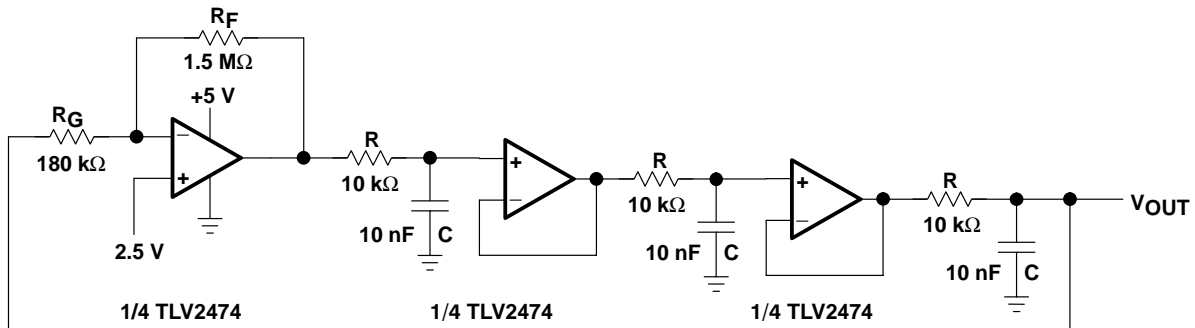

Figure 16. Phase-Shift Oscillator, Buffered

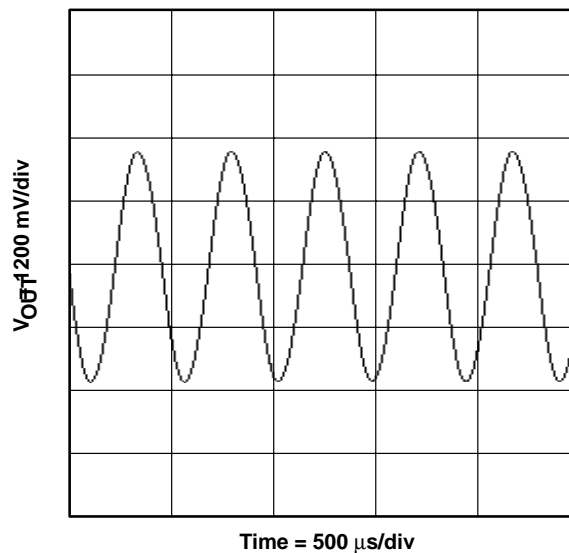

Figure 17. Output of the Circuit Figure 16



### 8.4 Bubba Oscillator

The bubba oscillator in Figure 18 is another phase-shift oscillator, but it takes advantage of the quad op-amp package to yield some unique advantages. Four RC sections require 45° phase shift per section, so this oscillator has an excellent  $d\phi/dt$  resulting in minimal frequency drift. The RC sections each contribute 45° phase shift, so taking outputs from alternate sections yields low-impedance quadrature outputs. When an output is taken from each op amp, the circuit delivers four 45° phase-shifted sine waves. The loop equation is given in equation 15. When  $\omega = 1/RCs$ , equation 15 reduces to equations 16 and 17.

$$A\beta = A\left(\frac{1}{RCs + 1}\right)^4 \tag{15}$$

$$|\beta| = \left| \left(\frac{1}{j + 4}\right)^4 \right| = \frac{1}{\sqrt{2}^4} = \frac{1}{4} \tag{16}$$

$$\phi = \tan^{-1}(1) = 45^\circ \tag{17}$$

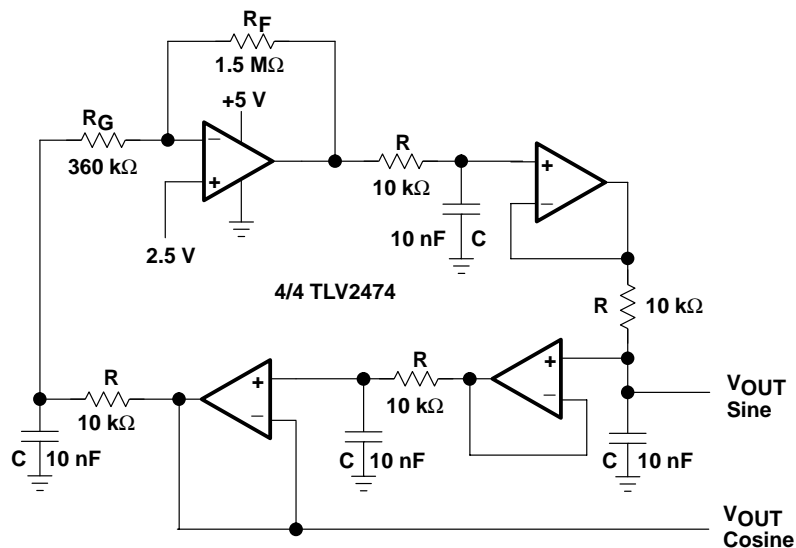
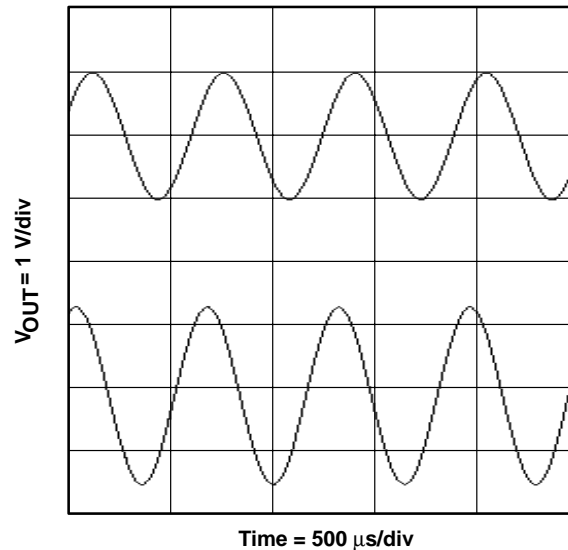

Figure 18. Bubba Oscillator



**Figure 19. Output of the Circuit in Figure 18**

The gain,  $A$ , must equal 4 for oscillation to occur. The test circuit oscillated at 1.76 kHz rather than the ideal frequency of 1.72 kHz when the gain was 4.17 rather than the ideal gain of 4. The output waveform is shown in Figure 19. Distortion was 1.1% for  $V_{OUTSINE}$  and 0.1% for  $V_{OUTCOSINE}$ . With low gain,  $A$ , and using low bias-current op amps, the gain-setting resistor,  $R_G$ , did not load the last RC section, thus ensuring oscillator frequency accuracy. Very low distortion sine waves can be obtained from the junction of  $R$  and  $R_G$ . When low-distortion sine waves are required at all outputs, the gain should be distributed among all the op amps. The noninverting input of the gain op amp is biased at 0.5 V to set the quiescent output voltage at 2.5 V for single-supply operation, and it should be ground for split-supply op amps. Gain distribution requires biasing of the other op amps, but it has no effect on the oscillator frequency.

## 8.5 Quadrature Oscillator

The quadrature oscillator shown in Figure 20 is another type of phase-shift oscillator, but the three RC sections are configured so each section contributes  $90^\circ$  of phase shift. This provides both sine and cosine waveform outputs (the outputs are *quadrature*, or  $90^\circ$  apart), which is a distinct advantage over other phase-shift oscillators. The idea of the quadrature oscillator is to use the fact that the double integral of a sine wave is a negative sine wave of the same frequency and phase, in other words, the original sine wave  $180^\circ$  phase shifted. The phase of the second integrator is then inverted and applied as positive feedback to induce oscillation [6].

The loop gain is calculated from equation 18. When  $R_1C_1 = R_2C_2 = R_3C_3$ , equation 18 reduces to equation 19. When  $\omega = 1/RC$ , equation 18 reduces to  $1\angle-180$ , so oscillation occurs at  $\omega = 2\pi f = 1/RC$ . The test circuit oscillated at 1.65 kHz rather than the calculated 1.59 kHz, as shown in Figure 21. This discrepancy is attributed to component variations. Both outputs have relatively high distortion that can be reduced with a gain-stabilizing circuit. The sine output had 0.846% distortion and the cosine output had 0.46% distortion. Adjusting the gain can increase the amplitudes. The penalty is reduced bandwidth.

$$A\beta = A \left( \frac{1}{R_1C_1s} \right) \left( \frac{R_3C_3s + 1}{R_3C_3s(R_2C_2s + 1)} \right) \quad (18)$$

$$A\beta = A\left(\frac{1}{RCs}\right)^2 \quad (19)$$

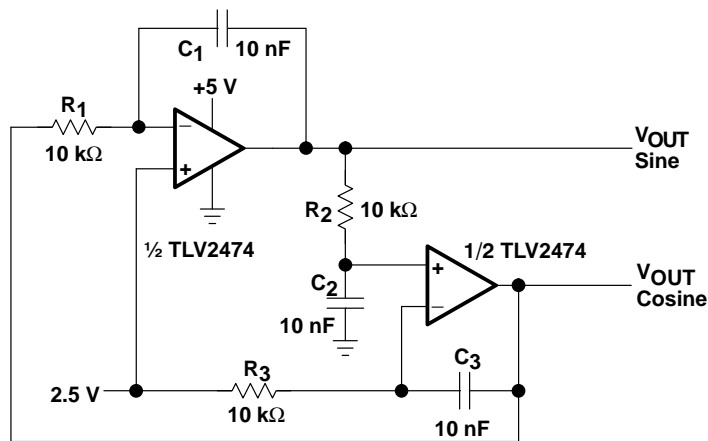

Figure 20. Quadrature Oscillator

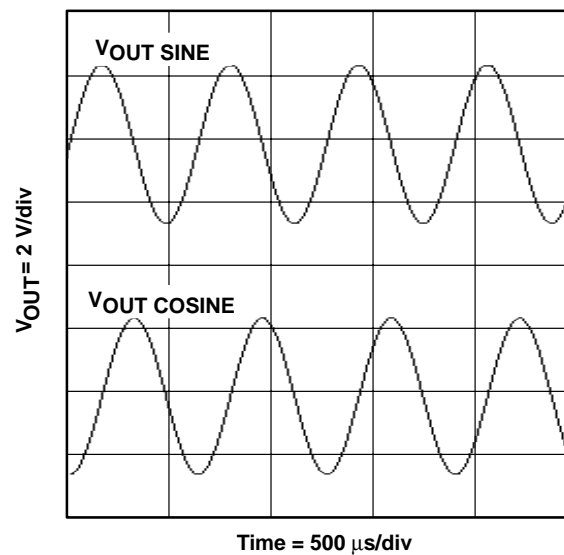

Figure 21. Output of the Circuit in Figure 20

## 9 Conclusion

Op-amp oscillators are restricted to the lower end of the frequency spectrum because they do not have the required bandwidth to achieve low phase shift at high frequencies. The new current-feedback op amps have a much greater bandwidth than their voltage-feedback counterparts, but they are very difficult to use in oscillator circuits because of their sensitivity to feedback capacitance. Voltage-feedback op amps are limited to a few hundred kHz (at the most) because of their low frequency rolloff. The bandwidth is reduced when op amps are cascaded due to the multiple contribution of phase shift.

The Wien-bridge oscillator has few parts and good frequency stability, but the basic circuit has high output distortion. AGC improves the distortion considerably, particularly in the lower frequency range. Nonlinear feedback offers the best performance over the mid- and upper-frequency ranges. The phase-shift oscillator has high output distortion and, without buffering, requires a high gain, which limits its use to very low frequencies. The decreasing cost of op amps and components has reduced the popularity of phase-shift oscillators. The quadrature oscillator only requires two op amps, has reasonable distortion, and offers both sine and cosine waveforms. The drawback is the low amplitude, which can be increased using an additional gain stage, but with the penalty of greatly reduced bandwidth.

## 10 References

1. Graeme, Jerald, *Optimizing Op Amp Performance*, McGraw Hill Book Company, 1997.
2. Gottlieb, Irving M., *Practical Oscillator Handbook*, Newnes, 1997.
3. Kennedy, E. J., *Operational Amplifier Circuits, Theory and Applications*, Holt Rhienshart and Winston, 1988.
4. Philbrick Researches, Inc., *Applications Manual for Computing Amplifiers*, Nimrod Press, Inc., 1966.
5. Graf, Rudolf F., *Oscillator Circuits*, Newnes, 1997.
6. Graeme, Jerald, *Applications of Operational Amplifiers, Third Generation Techniques*, McGraw Hill Book Company, 1973.
7. *Single Supply Op Amp Design Techniques*, Application Note, Texas Instruments Literature Number SLOA030.

## IMPORTANT NOTICE

Texas Instruments and its subsidiaries (TI) reserve the right to make changes to their products or to discontinue any product or service without notice, and advise customers to obtain the latest version of relevant information to verify, before placing orders, that information being relied on is current and complete. All products are sold subject to the terms and conditions of sale supplied at the time of order acknowledgment, including those pertaining to warranty, patent infringement, and limitation of liability.

TI warrants performance of its products to the specifications applicable at the time of sale in accordance with TI's standard warranty. Testing and other quality control techniques are utilized to the extent TI deems necessary to support this warranty. Specific testing of all parameters of each device is not necessarily performed, except those mandated by government requirements.

Customers are responsible for their applications using TI components.

In order to minimize risks associated with the customer's applications, adequate design and operating safeguards must be provided by the customer to minimize inherent or procedural hazards.

TI assumes no liability for applications assistance or customer product design. TI does not warrant or represent that any license, either express or implied, is granted under any patent right, copyright, mask work right, or other intellectual property right of TI covering or relating to any combination, machine, or process in which such products or services might be or are used. TI's publication of information regarding any third party's products or services does not constitute TI's approval, license, warranty or endorsement thereof.

Reproduction of information in TI data books or data sheets is permissible only if reproduction is without alteration and is accompanied by all associated warranties, conditions, limitations and notices. Representation or reproduction of this information with alteration voids all warranties provided for an associated TI product or service, is an unfair and deceptive business practice, and TI is not responsible nor liable for any such use.

Resale of TI's products or services with statements different from or beyond the parameters stated by TI for that product or service voids all express and any implied warranties for the associated TI product or service, is an unfair and deceptive business practice, and TI is not responsible nor liable for any such use.

Also see: [Standard Terms and Conditions of Sale for Semiconductor Products](http://www.ti.com/sc/docs/stdterms.htm). [www.ti.com/sc/docs/stdterms.htm](http://www.ti.com/sc/docs/stdterms.htm)

### Mailing Address:

Texas Instruments  
Post Office Box 655303  
Dallas, Texas 75265